

## HS-2500A Technical Data Sheet

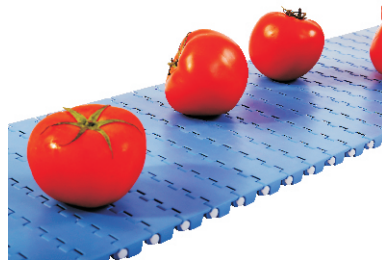
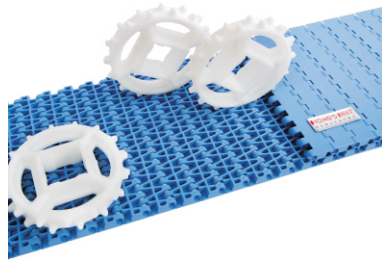
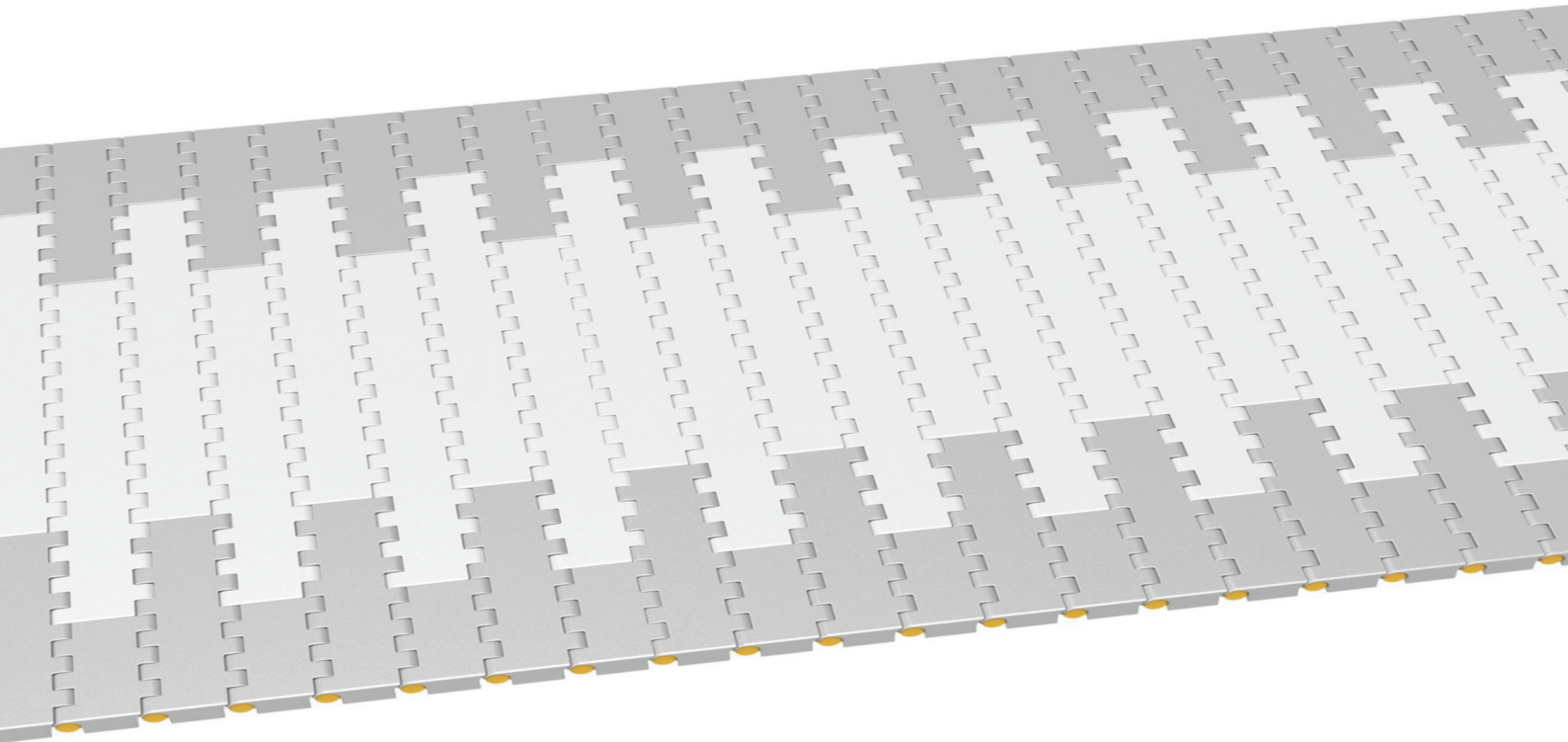

<p>Pitch: 25.4mm</p> <p>Minimum Width: 50mm</p> <p>Open Area: 0%</p> <p>Approved: FDA</p> <p>Rod: Ø 4.9mm</p> <p>Flight: Yes</p> <p>Side Guard: No</p> <p>Curve : No</p>	
--	--

## Data

Belt Material	Belt Strength Kg/M (BW)			Temperature		Belt Weight (Kg/M <sup>2</sup> )
	Straight		Curve	°C (min.)	°C (max.)	
	Kg/M(BW)	N/M(BW)				
Polypropylene	1060	10600	--	1	110	5.8
Polyethylene	1030	10300	--	-60	60	6.1
Acetal	1720	17200	--	-40	85	8.8
Nylon	1520	15200	--	1	160	7.9

**BW – Belt Width**

## Color Table

Polypropylene					Polyethylene					Acetal					Nylon				
W	G	N	DB	B	W	G	N	DB	B	W	G	N	DB	B	W	G	N	DB	B
●	●						●			●				●				●	

W-White, G-Gray, N-Nature, DB-Dark brown, B-Blue

## Friction Tables

Belt Material	Friction Wearstrips & Products							
	UHMW	HDPE	Steel	Glass	SUS	Plastic	Cardboard	Aluminum
Polypropylene	0.32	0.24	0.15	0.09	0.13	0.08	0.15	0.25
Polyethylene	0.13	0.11	0.26	0.19	0.31	0.16	0.21	0.41
Acetal	0.11	0.09	0.27	0.16	0.26	0.15	0.19	0.28
Nylon	0.18	0.13	0.25	0.16	0.26	0.16	0.19	0.27

SUS – Stainless Steel

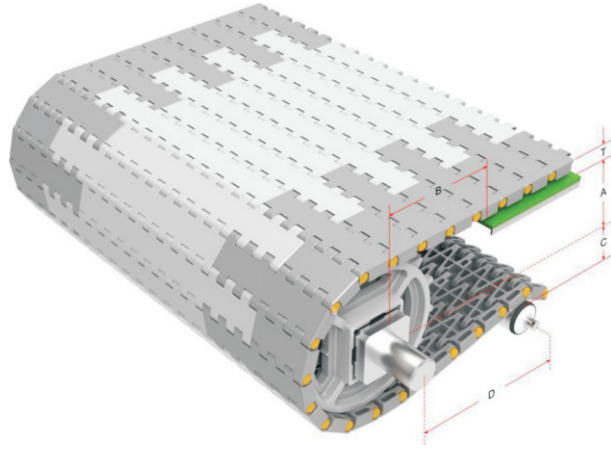

**Conveyor Frame Dimensions**

Unit : mm

No. Teeth	A ( Min.)	B ( Min.)	C ( Max.)	D ( Min.)	T
8-2R	27.8	42.8	26.8	200	10
10-2R	36.25	51.25	35.25	200	
12-2R	44.5	59.5	43.5	200	
15-2R	57	72	56	200	
16-2R	60.57	75.75	59.75	200	
18-2R	69.25	84.25	68.25	200	
20-2R / 20-2R-Split	77.25	92.25	76.25	200	

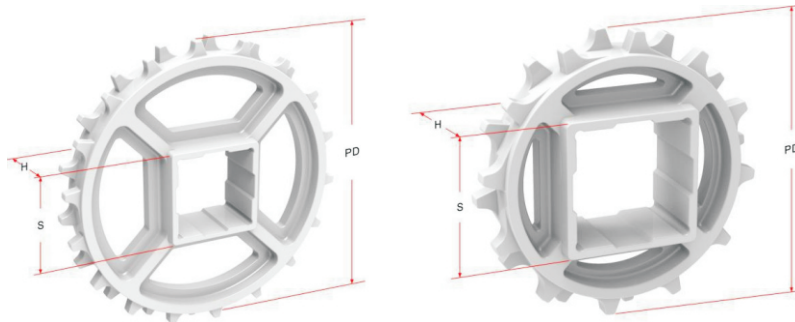

**Sprocket Dimensions**

Unit: mm

No. Teeth	PD	S	D	H	K
8-2R	65.6	--	30	30	8X8
10-2R	82.5	25.4/38.5/40.5	30.2/31.75	30	8X8
12-2R	99	38.5/40.5	25/25.4/30/32	30	8X8
15-2R	124	38.5/40.5	25.5/30/30.5/35.5	30	8X8
16-2R	131.5	38.5/40.5	--	30	--
18-2R	148.5	38.5/40.5/60.5	25.4/25.5/30.5/31.75	30	8X8
20-2R	164.5	38.5/40.5/60.5/70.5	--	30	--
20-2R-Split	164.5	38.5/40.5/60.5	--	40	--